



## Specification

Non-key

W200-key

Dimple-key



## Part Numbers

Dimple-Key	<b>WS - L300 - F</b>	<b>F</b> = Surface Finish Code 03 = Non-Glossy Chrome 04 = Black Chrome 05 = Black Paint
W200-Key	<b>WS - L301 - F</b>	
Non-Key	<b>WS - L302 - F</b>	

# Draw Latch

- Bracket 멈춤장치로 추가로 합체와 래치의 조립이 용이함
- 세련된 디자인
- 재 질: 아연 합금, 그외 : 스테인레스
- 표면처리: 무광, 흑색크롬도금
- The fabrication of the body and latch becomes easy by adding the bracket-Stop device
- Material : Zinc Alloy, Stainless Steel
- Finish : Chrome plated Non-Glossy or Black

## WS-L300 Draw Latch

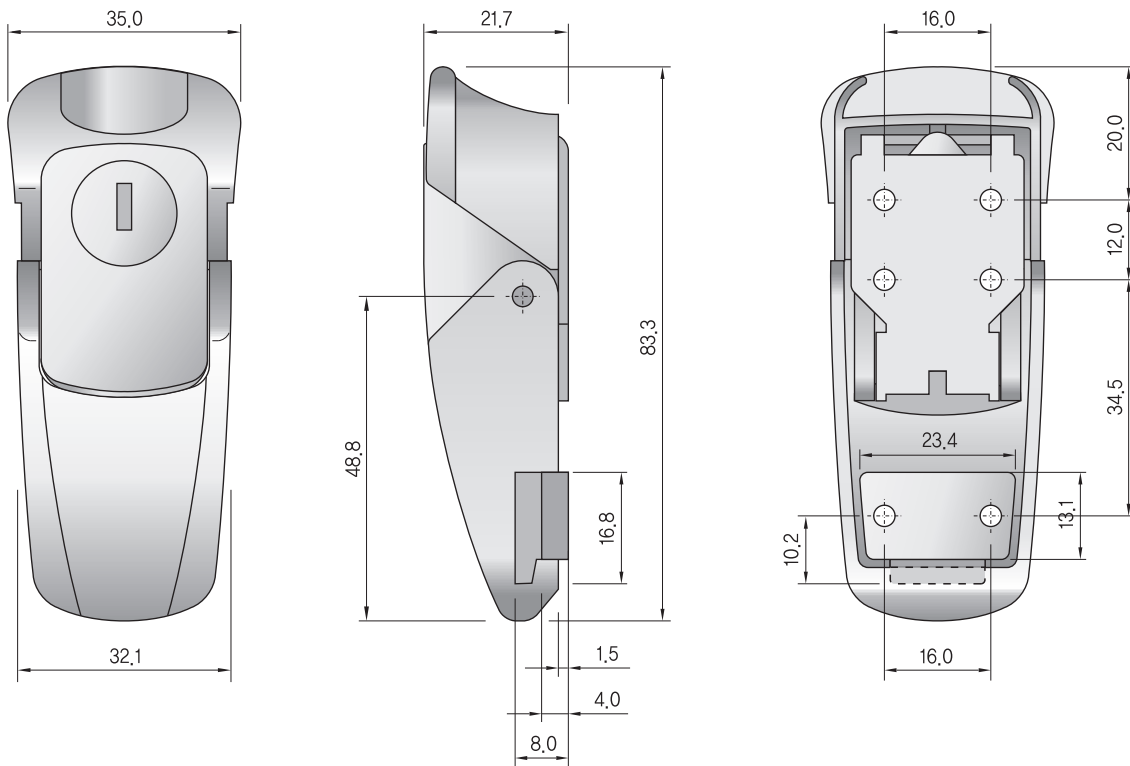

### Bracket Stopper

PCT 국제 특허 출원 PCT/KR2010/006204  
 특허 출원 제 10-2010-0089258, 2010-0035736호

- Bracket Stopper(멈춤장치)가 있어 합체와 래치의 조립성이 타사의 제품보다 월등함
- 1인 작업으로 생산성 증가

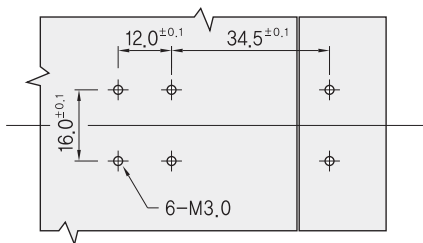

Tapping Dimensions

