

Dwg. No.

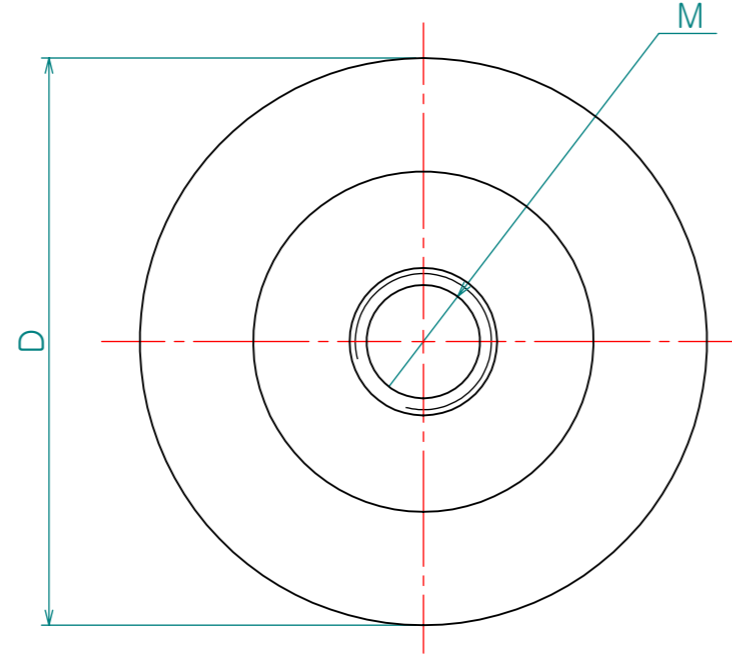

Re. No.	DESCRIPTION	DATE	DS.	CH.	AP.
△					
△					
△					

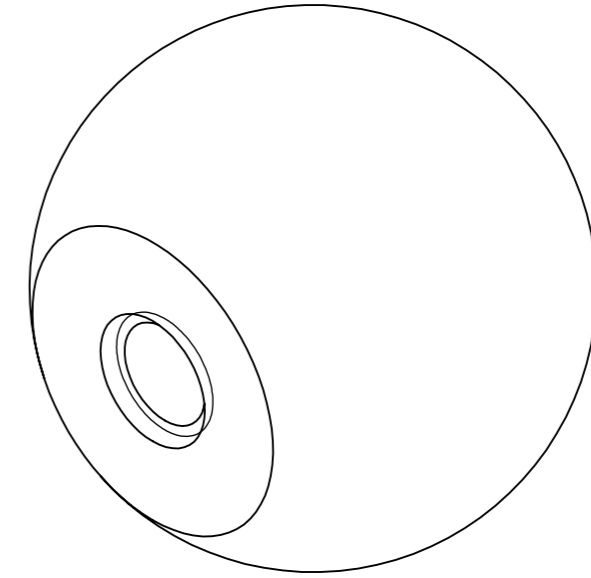
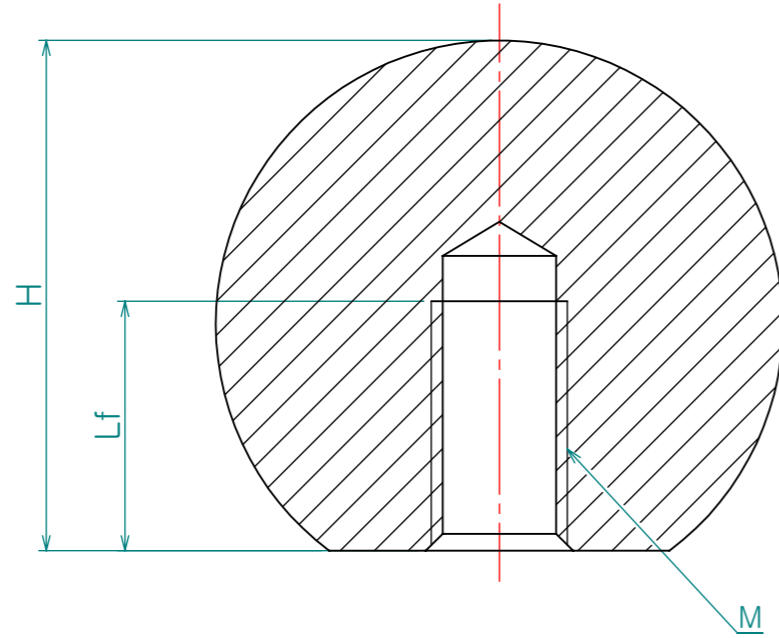

제품명	M (일반나사)	D	H	Lf
CA-1042-S3	3	15	13	8
CA-1042-S4	4	20	18	9.1
CA-1042-S5	5	20	18	9.1
CA-1042-S6	6	25	22.5	11
CA-1042-S8	8	32	29	14.5
CA-1042-S10	10	40	37	18

Note

1. 특징 :
2. 용도 :

Dimension (mm)	Precision	Material	Dwg. No.	QTY
0.5~3		<b>SUS304</b>		*EA
3~6	±0.05	Finish	Part Name.	Weight
6~30	±0.1	<b>Buffing polishing</b>	**	-
30~120	±0.15	Revision	Sheet Size	Scale
120~315	±0.2	-	<b>A3</b>	3:1
315~1000	±0.3	Date	Designed by	Model No.
1000~2000	±0.5	2014-10-30	<i>Shin S H</i>	<b>CA-1042</b>
KS B 0412에 준함		Checked by	Approved by	